

DROFIRE VTS P1M

DATI TECNICI TECHNICAL DATA

MODELLO GRUPPO	MOTOPOMPA					ELETTROPOMPA PILOTA		LINEA D'ASSE	KIT FLUSSIMETRO
	motore diesel			rinvio ad angolo		JOCKEY PUMP		LINESHAFT	FLOW METER KIT
MODEL GROUP	MOTOR PUMP			right angle drive unit					
	diesel engine								
VTS P1M	mod.	kW NA	kW NA	mod.	DN	mod.	kW	mod.	mod.
EN VTS P1M 6G/4A LC+S4/11	15LD440	6,2	6,7	R16/3L/20	80	S4/11	0,75	LA3/20	CM50 - V50
EN VTS P1M 6G/6A LC+S4/16	25LD425	10,4	11,5	R16/3L/20	80	S4/16	1,1	LA3/20	CM50 - V50
EN VTS P1M 6G/8A LC+S4/21	12LD477/2	13,6	15	R16/3L/20	80	S4/21	1,5	LA3/20	CM50 - V50
EN VTS P1M 6G/10A LC+S4/32	9LD625/2	17	18,9	R16/3L/20	80	S4/32	2,2	LA3/20	CM50 - V50
EN VTS P1M 6G/12A LC+S4/32	9LD625/2	17	18,9	R16/3L/20	80	S4/32	2,2	LA3/20	CM50 - V50
EN VTS P1M 6C/4A LC+S4/11	25LD425	10,4	11,5	R16/3L/20	80	S4/11	0,75	LA3/20	CM65 - V50
EN VTS P1M 6C/6A LC+S4/21	12LD477/2	13,6	15	R16/3L/20	80	S4/21	1,5	LA3/20	CM65 - V50
EN VTS P1M 6C/8A LC+S4/21	9LD625/2	17	18,9	R16/3L/20	80	S4/21	1,5	LA3/20	CM65 - V50
EN VTS P1M 6C/10A LC+S4/32	11LD626/3	24	26	R16/3L/24	80	S4/32	2,2	LA3/24	CM65 - V50
EN VTS P1M 7L/3A LC+S4/11	25LD425	10,4	11,5	R16/3L/20	80	S4/11	0,75	LA3/20	CM65 - V65
EN VTS P1M 7L/4A LC+S4/16	12LD477/2	13,6	15	R16/3L/20	80	S4/16	1,1	LA3/20	CM65 - V65
EN VTS P1M 7L/5A LC+S4/21	9LD625/2	17	18,9	R16/3L/20	80	S4/21	1,5	LA3/20	CM65 - V65
EN VTS P1M 7L/6A LC+S4/21	11LD626/3	24	26	R16/3L/20	80	S4/21	1,5	LA3/20	CM65 - V65
EN VTS P1M 7L/7A LC+S4/32	11LD626/3	24	26	R16/3L/24	80	S4/32	2,2	LA3/24	CM65 - V65
EN VTS P1M 7L/8A VC+S4/32	D703LE0	33	37	R16/3L/24	80	S4/32	2,2	LA3/24	CM65 - V65
EN VTS P1M 7L/9A VC+S4/32	D703LE0	33	37	R16/3L/24	80	S4/32	2,2	LA3/24	CM65 - V65
EN VTS P1M 7C/2A LC+S4/11	25LD425	10,4	11,5	R16/4L/20	100	S4/11	0,75	LA4/20	CM80 - V65
EN VTS P1M 7C/3A LC+S4/11	9LD625/2	17	18,9	R16/4L/20	100	S4/11	0,75	LA4/20	CM80 - V65
EN VTS P1M 7C/4A LC+S4/16	11LD626/3	24	26	R16/4L/20	100	S4/16	1,1	LA4/20	CM80 - V65
EN VTS P1M 7C/5A VC+S4/21	D703LE0	33	37	R26/4L/24	100	S4/21	1,5	LA4/24	CM80 - V65
EN VTS P1M 7C/6A VC+S4/21	D703LE0	33	37	R26/4L/24	100	S4/21	1,5	LA4/24	CM80 - V65
EN VTS P1M 7C/7A VC+S4/32	D703LTE0	48	53	R26/4L/24	100	S4/32	2,2	LA4/24	CM80 - V65
EN VTS P1M 8B/2A LC+S4/11	25LD425	10,4	11,5	R16/3L/20	80	S4/11	0,75	LA3/20	CM65 - V65
EN VTS P1M 8B/3A LC+S4/16	9LD625/2	17	18,9	R16/3L/20	80	S4/16	1,1	LA3/20	CM65 - V65
EN VTS P1M 8B/4A LC+S4/21	11LD626/3	24	26	R16/3L/20	80	S4/21	1,5	LA3/20	CM65 - V65
EN VTS P1M 8B/5A VC+S4/32	D703LE0	33	37	R26/3L/24	80	S4/32	2,2	LA3/24	CM65 - V65
EN VTS P1M 8B/6A VC+S4/32	D703LE0	33	37	R26/3L/24	80	S4/32	2,2	LA3/24	CM65 - V65
EN VTS P1M 8F/2A LC+S4/11	12LD477/2	13,6	15	R16/4L/20	100	S4/11	0,75	LA4/20	CM80 - V65
EN VTS P1M 8F/3A LC+S4/16	9LD625/2	17	18,9	R16/4L/20	100	S4/16	1,1	LA4/20	CM80 - V65
EN VTS P1M 8F/4A LC+S4/21	11LD626/3	24	26	R26/4L/24	100	S4/21	1,5	LA4/24	CM80 - V65
EN VTS P1M 8F/5A VC+S4/21	D703LE0	33	37	R26/4L/24	100	S4/21	1,5	LA4/24	CM80 - V65
EN VTS P1M 8F/6A VC+S4/32	D703LTE0	48	53	R26/4L/24	100	S4/32	2,2	LA4/24	CM80 - V65
EN VTS P1M 8L/2A LC+S4/11	12LD477/2	13,6	15	R16/5/20	125	S4/11	0,75	LA5/20	CM80 - V80
EN VTS P1M 8L/3A LC+S4/16	11LD626/3	24	26	R16/5/20	125	S4/16	1,1	LA5/20	CM80 - V80
EN VTS P1M 8L/4A VC+S4/21	D703LE0	33	37	R26/5/24	125	S4/21	1,5	LA5/24	CM80 - V80
EN VTS P1M 8L/5A VC+S4/21	D703LE0	33	37	R26/5/24	125	S4/21	1,5	LA5/24	CM80 - V80
EN VTS P1M 8L/6A VC+S4/32	D703LTE0	48	53	R26/5/24	125	S4/32	2,2	LA5/24	CM80 - V80
EN VTS P1M 8C/2A LC+S4/11	9LD625/2	17	18,9	R16/5/20	125	S4/11	0,75	LA5/20	CM100 - V80
EN VTS P1M 8C/3A VC+S4/16	D703LE0	33	37	R26/5/24	125	S4/16	1,1	LA5/24	CM100 - V80
EN VTS P1M 8C/4A VC+S4/21	D703LTE0	48	53	R26/5/24	125	S4/21	1,5	LA5/24	CM100 - V80
EN VTS P1M 8C/5A VC+S4/32	D703LTE0	48	53	R42/5/30	125	S4/32	2,2	LA5/30	CM100 - V80
EN VTS P1M 8C/6A VC+S4/32	D754TPE2	65	73	R42/5/30	125	S4/32	2,2	LA5/30	CM100 - V80
EN VTS P1M 10F/1B VC+S4/11	D703LE0	33	37	R26/6/24	125	S4/11	0,75	LA6/24	CM150 - V125
EN VTS P1M 10F/1A VC+S4/11	D703LTE0	48	53	R26/6/30	150	S4/11	0,75	LA6/30	CM150 - V125
EN VTS P1M 10F/2E VC+S4/11	D703LTE0	48	53	R42/6/30	150	S4/11	0,75	LA6/30	CM150 - V125
EN VTS P1M 10F/2CD VC+S4/16	D754TPE2	65	73	R42/6/30	150	S4/16	1,1	LA6/30	CM150 - V125
EN VTS P1M 10F/2BC VC+S4/16	D754TPE2	65	73	R42/6/30	150	S4/16	1,1	LA6/30	CM150 - V125
EN VTS P1M 10F/3CD VC+S4/21	D756IPE2	100	110	R75/6/30	150	S4/21	1,5	LA6/30	CM150 - V125
EN VTS P1M 10F/3B VC+S4/21	D756IPE2	100	110	R75/6/30	150	S4/21	1,5	LA6/30	CM150 - V125
EN VTS P1M 12B/1B VC+S4/11	D703LTE0	48	53	R26/7/30	175	S4/11	0,75	LA7/30	CM125 - V125
EN VTS P1M 12B/1A VC+S4/11	D703LTE0	48	53	R42/7/30	175	S4/11	0,75	LA7/30	CM125 - V125
EN VTS P1M 12B/2C VC+S4/21	D754TPE2	65	73	R75/7/30	175	S4/21	1,5	LA7/30	CM125 - V125
EN VTS P1M 12B/2B VC+S4/21	D756IPE2	100	110	R75/7/30	175	S4/21	1,5	LA7/30	CM125 - V125
EN VTS P1M 12B/3C VC+S4/32	D756IPE2	100	110	R75/7/30	175	S4/32	2,2	LA7/30	CM125 - V125

IDROFIRE VTS P1M

DIMENSIONI DIMENSIONS

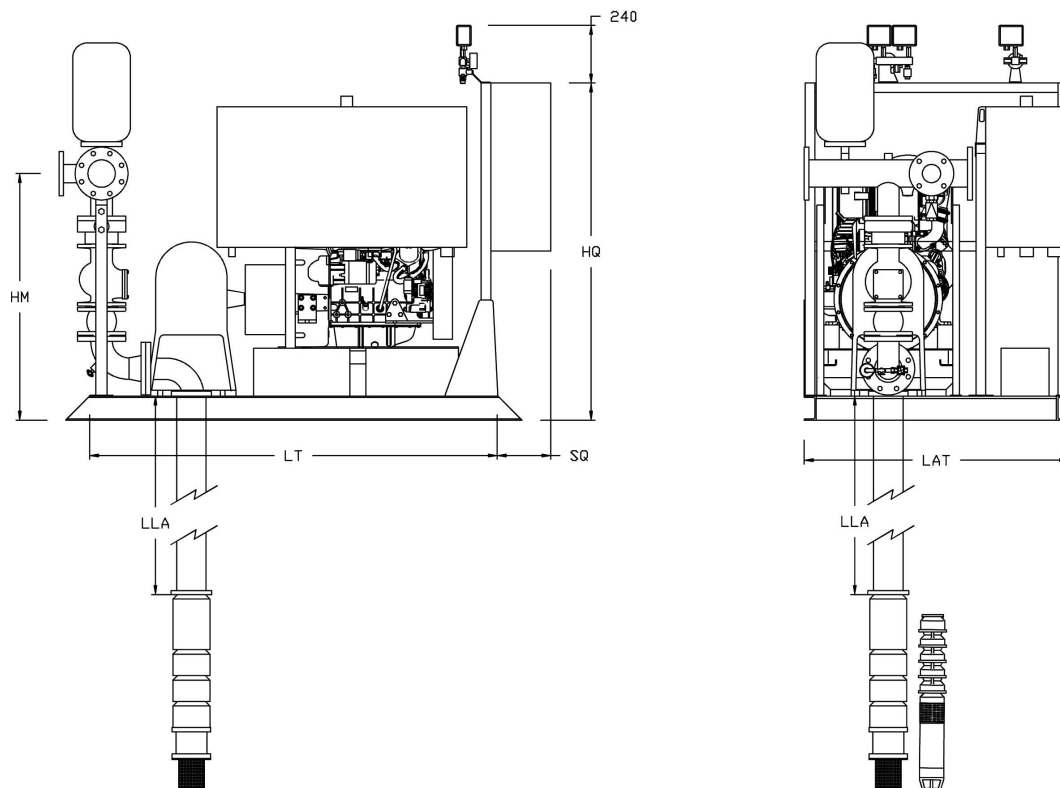

MODELLO GRUPPO	MANDATA kit valvole	collettore	PILOTA	HM	LAT	LT	LC	HQ	SQ	LLA
MODEL GROUP	DELIVERY valves kit	manifold	JOCKEY PUMP	HM	LAT	LT	LC	HQ	SQ	LLA
VTS P1M	DN	DN	DN AxM	mm	mm	mm	mm	mm	mm	mm
EN VTS P1M 6G/4A LC+S4/11	50	80 - F50	1¼"	997	1000	1400	700	1400	230	3050
EN VTS P1M 6G/6A LC+S4/16	50	80 - F50	1¼"	997	1000	1400	700	1401	230	3050
EN VTS P1M 6G/8A LC+S4/21	50	80 - F50	1¼"	997	1000	1600	700	1402	230	3050
EN VTS P1M 6G/10A LC+S4/32	50	80 - F50	1¼"	997	1200	1600	900	1403	230	3050
EN VTS P1M 6G/12A LC+S4/32	50	80 - F50	1¼"	997	1200	1600	900	1404	230	3050
EN VTS P1M 6C/4A LC+S4/11	65	80 - F50	1¼"	1050	1000	1400	700	1405	230	3050
EN VTS P1M 6C/6A LC+S4/21	65	80 - F50	1¼"	1050	1000	1600	700	1406	230	3050
EN VTS P1M 6C/8A LC+S4/21	65	80 - F50	1¼"	1050	1200	1600	900	1407	230	3050
EN VTS P1M 6C/10A LC+S4/32	65	80 - F50	1¼"	1050	1400	1800	1100	1408	230	3050
EN VTS P1M 7L/3A LC+S4/11	80	100 - F65	1¼"	1047	1000	1400	700	1409	230	3050
EN VTS P1M 7L/4A LC+S4/16	80	100 - F65	1¼"	1047	1000	1600	700	1410	230	3050
EN VTS P1M 7L/5A LC+S4/21	80	100 - F65	1¼"	1047	1200	1600	900	1411	230	3050
EN VTS P1M 7L/6A LC+S4/21	80	100 - F65	1¼"	1047	1400	1800	1100	1412	230	3050
EN VTS P1M 7L/7A LC+S4/32	80	100 - F65	1¼"	1047	1400	1800	1100	1413	230	3050
EN VTS P1M 7L/8A VC+S4/32	80	100 - F65	1¼"	1047	1000	1800	700	1414	230	3050
EN VTS P1M 7L/9A VC+S4/32	80	100 - F65	1¼"	1047	1000	1800	700	1415	230	3050
EN VTS P1M 7C/2A LC+S4/11	80	100 - F65	1¼"	1047	1000	1400	700	1416	230	3050
EN VTS P1M 7C/3A LC+S4/11	80	100 - F65	1¼"	1047	1200	1600	900	1417	230	3050
EN VTS P1M 7C/4A LC+S4/16	80	100 - F65	1¼"	1047	1400	1800	1100	1418	230	3050
EN VTS P1M 7C/5A VC+S4/21	80	100 - F65	1¼"	1047	1000	1800	700	1419	230	3050
EN VTS P1M 7C/6A VC+S4/21	80	100 - F65	1¼"	1047	1000	1800	700	1420	230	3050
EN VTS P1M 7C/7A VC+S4/32	80	100 - F65	1¼"	1047	1000	1800	700	1421	230	3050
EN VTS P1M 8B/2A LC+S4/11	80	100 - F65	1¼"	1047	1000	1400	700	1422	230	3050
EN VTS P1M 8B/3A LC+S4/16	80	100 - F65	1¼"	1047	1200	1600	900	1423	230	3050
EN VTS P1M 8B/4A LC+S4/21	80	100 - F65	1¼"	1047	1400	1800	1100	1424	230	3050
EN VTS P1M 8B/5A VC+S4/32	80	100 - F65	1¼"	1047	1000	1800	700	1425	230	3050
EN VTS P1M 8B/6A VC+S4/32	80	100 - F65	1¼"	1047	1000	1800	700	1426	230	3050

IDROFIRE VTS P1M

DIMENSIONI DIMENSIONS

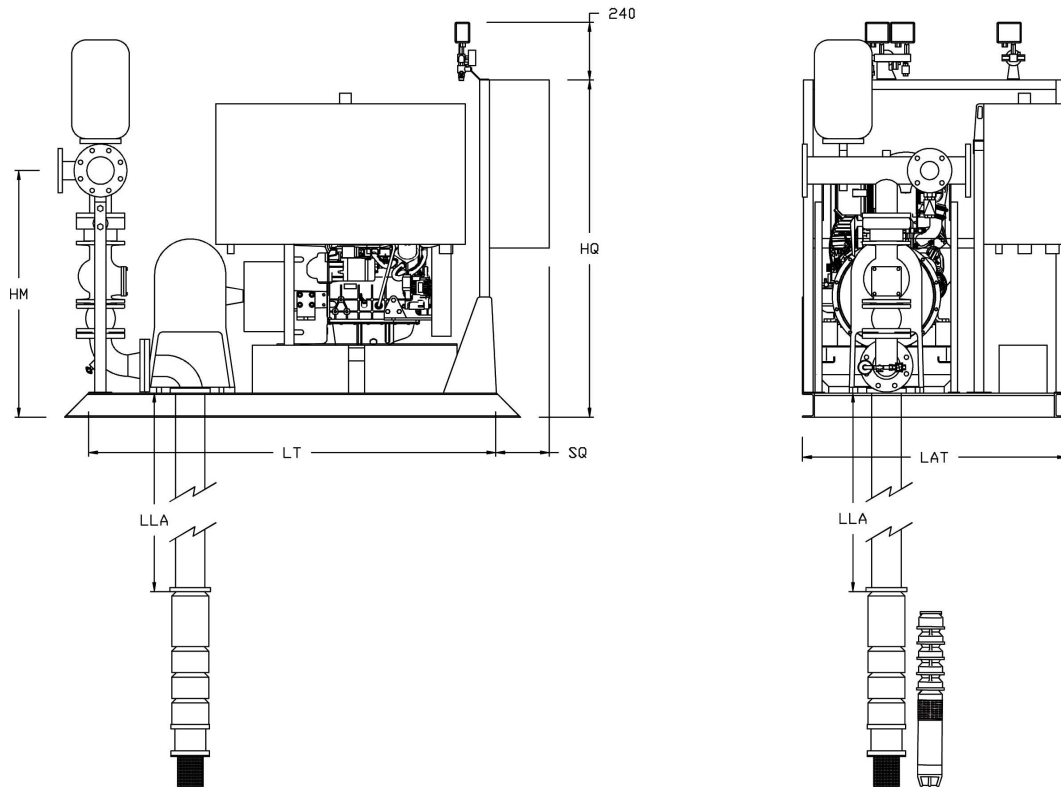

MODELLO GRUPPO	MANDATA kit valvole	collettore	PILOTA	HM	LAT	LT	LC	HQ	SQ	LLA
MODEL GROUP	DELIVERY valves kit	manifold	JOCKEY PUMP	HM	LAT	LT	LC	HQ	SQ	LLA
VTS P1M	DN	DN	DN AxM	mm	mm	mm	mm	mm	mm	mm
EN VTS P1M 8F/2A LC+S4/11	80	100 - F65	1¼"	1047	1000	1600	700	1427	230	3050
EN VTS P1M 8F/3A LC+S4/16	80	100 - F65	1¼"	1047	1200	1600	900	1428	230	3050
EN VTS P1M 8F/4A LC+S4/21	80	100 - F65	1¼"	1047	1400	1800	1100	1429	230	3050
EN VTS P1M 8F/5A VC+S4/21	80	100 - F65	1¼"	1047	1000	1800	700	1430	230	3050
EN VTS P1M 8F/6A VC+S4/32	80	100 - F65	1¼"	1047	1000	1800	700	1431	230	3050
EN VTS P1M 8L/2A LC+S4/11	100	125 - F80	1¼"	1169	1000	1600	700	1432	230	3050
EN VTS P1M 8L/3A LC+S4/16	100	125 - F80	1¼"	1169	1400	1800	1100	1433	230	3050
EN VTS P1M 8L/4A VC+S4/21	100	125 - F80	1¼"	1169	1000	2000	700	1434	230	3050
EN VTS P1M 8L/5A VC+S4/21	100	125 - F80	1¼"	1169	1000	2000	700	1435	230	3050
EN VTS P1M 8L/6A VC+S4/32	100	125 - F80	1¼"	1169	1000	2000	700	1436	230	3050
EN VTS P1M 8C/2A LC+S4/11	100	125 - F80	1¼"	1169	1200	1600	900	1437	230	3050
EN VTS P1M 8C/3A VC+S4/16	100	125 - F80	1¼"	1169	1000	2000	700	1438	230	3050
EN VTS P1M 8C/4A VC+S4/21	100	125 - F80	1¼"	1169	1000	2000	700	1439	230	3050
EN VTS P1M 8C/5A VC+S4/32	100	125 - F80	1¼"	1199	1000	2000	700	1440	230	3050
EN VTS P1M 8C/6A VC+S4/32	100	125 - F80	1¼"	1199	1000	2300	700	1441	230	3050
EN VTS P1M 10F/1B VC+S4/11	150	200 - F125	1¼"	1434	1000	2000	700	1442	230	3050
EN VTS P1M 10F/1A VC+S4/11	150	200 - F125	1¼"	1464	1000	2000	700	1443	230	3050
EN VTS P1M 10F/2E VC+S4/11	150	200 - F125	1¼"	1464	1000	2000	700	1444	230	3050
EN VTS P1M 10F/2CD VC+S4/16	150	200 - F125	1¼"	1464	1000	2300	700	1445	230	3050
EN VTS P1M 10F/2BC VC+S4/16	150	200 - F125	1¼"	1464	1000	2300	700	1446	230	3050
EN VTS P1M 10F/3CD VC+S4/21	150	200 - F125	1¼"	1464	1000	2500	700	1447	230	3050
EN VTS P1M 10F/3B VC+S4/21	150	200 - F125	1¼"	1464	1000	2500	700	1448	230	3050
EN VTS P1M 12B/1B VC+S4/11	150	200 - F125	1¼"	1464	1000	2000	700	1449	230	3050
EN VTS P1M 12B/1A VC+S4/11	150	200 - F125	1¼"	1464	1000	2000	700	1450	230	3050
EN VTS P1M 12B/2C VC+S4/21	150	200 - F125	1¼"	1464	1000	2300	700	1451	230	3050
EN VTS P1M 12B/2B VC+S4/21	150	200 - F125	1¼"	1464	1000	2500	700	1452	230	3050
EN VTS P1M 12B/3C VC+S4/32	150	200 - F125	1¼"	1464	1000	2500	700	1453	230	3050